

DL3500

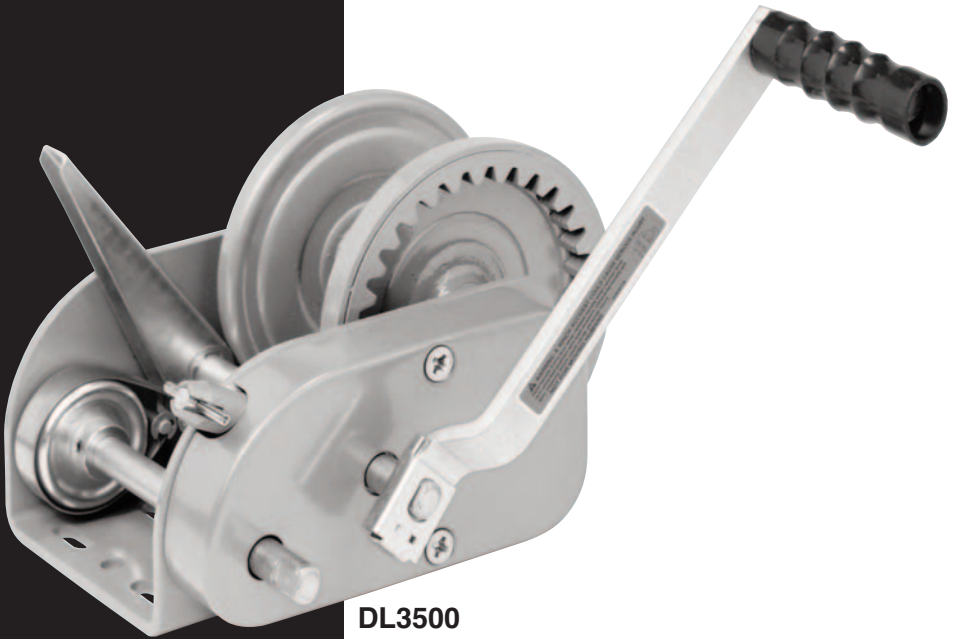

PULLING WINCH



DL3500

A Dependable Company Since 1886

DUTTON-LAINSON COMPANY

Hastings, NE 68902 U.S.A • Tel 402-462-4141 • Fax 402-460-4612
E-mail dlsales@dutton-lainson.com • Web Site www.dutton-lainson.com

ISO 9001: 2008 REGISTERED Q.M.S.

**MADE IN
USA**



! WARNING READ INSTRUCTIONS CAREFULLY BEFORE ATTEMPTING TO INSTALL, OPERATE OR SERVICE THIS WINCH. FAILURE TO COMPLY WITH INSTRUCTIONS COULD RESULT IN SERIOUS OR FATAL INJURY. RETAIN THESE INSTRUCTIONS FOR FUTURE REFERENCE.



IMPORTANT SAFETY INFORMATION

- This winch is built for multi-purpose hauling and pulling operations. It is not recommended for lifting applications. For lifting, use a self-locking winch. DL winches are not to be used as hoists for lifting, supporting or transporting people, or for loads over areas where people could be present.
- Respect this winch. High forces are created when using a winch, creating potential safety hazards. It should be operated and maintained in accordance with instructions. Never allow children or anyone who is not familiar with the operation of the winch to use it.
- Maintain a firm grip on the winch handle at all times, and never release the handle when ratchet lever is in unlocked position with a load on the winch. Otherwise, handle will spin violently, which could cause personal injury.
- Check for proper ratchet operation on each use of the winch. Do not use if damaged. Seek immediate repairs.
- Never use the winch handle as a convenient handle for pulling or maneuvering the entire trailer or other equipment. Never pull on the winch handle against a locked ratchet.
- Never exceed rated capacity. Excess load may cause premature failure and could result in serious personal injury. This winch is rated with three layers of line on the hub. Using more layers of line or a large hub increases the load on the winch.
- Never apply load on winch with cable or rope fully extended. Keep at least three full turns of cable or rope on the reel.
- Secure load properly. When winching operation is complete, do not depend on winch to support load.
- Operate with hand power only. This winch should not be operated with a motor of any kind. If the winch cannot be cranked easily with one hand, it is probably over-loaded.

WINCH MOUNTING AND CABLE ATTACHMENT

— For maximum strength and safety (and compliance with SAE Standard J1853), this winch must be attached to the mounting surface with a minimum of three 3/8" grade 5 or grade 8 bolts, washers and lock washers. Place one bolt in the slot under the reel and two in either set of slots at the opposite end of the base as shown in the drawing on back of page.

Select a winch line with breaking strength at least 1-1/2 times the winch rating and a hook 1-1/2 times stronger than the line. If steel cable is selected, the optional reel with large hub may extend cable life. (The above combination meets SAE Standard J1853 for boat trailer winches). Attach cable or rope by method described in sketch. Keep at least three full turns of cable or rope on the reel.

OPERATING INSTRUCTIONS

— Attach winch handle securely to primary drive shaft (lower or low-speed shaft). Make sure the handle clip engages with groove in drive shaft. Engage ratchet plunger by placing pin in the horizontal position in the deep slot. Wind line on winch reel by turning winch handle in counterclockwise direction. (NOTE: If the winch handle refuses to turn, pull the ratchet plunger pin from slot, turn 180 degrees, and re-engage.) The ratchet plunger should bob up and down as line is wound onto the reel. Make sure that the ratchet plunger is fully engaged and holding load before winch handle is released. To unwind or reel out line, securely grip the winch handle and apply force in counterclockwise direction so that ratchet plunger can be easily disengaged. Pull ratchet

plunger pin up and turn 90 degrees. Apply force to hand brake to help hold load while carefully turning handle in clockwise direction. Do not lose control. After reeling out line, lock load in position by re-engaging ratchet plunger. Check to be certain that it bobs up and down when the handle is turned counterclockwise and that it is securely holding the load before releasing handle.

If handle is attached to intermediate (upper or high-speed shaft), operate winch as described above, reversing clockwise and counterclockwise. This winch is also equipped with a two-way ratchet feature so that it can be used to wind line onto the underside of the reel. Operate as described above, reversing clockwise and counterclockwise.

WINCH MAINTENANCE — This winch has been fully lubricated at the factory; but, for continued smooth performance and increased life, occasional greasing of gears and reel shaft and an occasional drop of oil on drive shaft bearings are recommended.

Do not oil or grease brake mechanism. Keep winch in good working order. Damaged or severely-worn parts create unnecessary dangers and could result in personal injury or property damage.

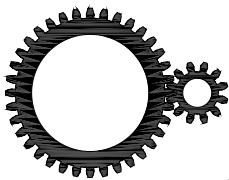

12:1/6:1

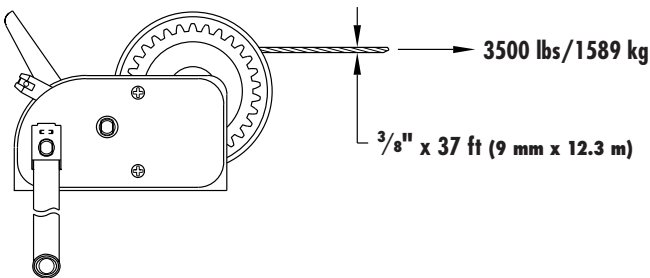

ENGLISH – DECLARATION OF CONFORMITY - Dutton-Lainson Company, Hastings, NE 68902-0729 U.S.A. manufactures and declares that the winch identified above fulfills all relevant provisions of the Directive 2006/42/EC. The technical file may be obtained from the persons listed below.

DEUTSCH – KONFORMITÄTSERKLÄRUNG - Dutton-Lainson Company, Hastings, NE 68902-0729, USA, der Hersteller der Winde, erklärt, dass die oben angegebene Winde alle relevanten Bestimmungen der Richtlinie 2006/42/EG erfüllt. Die technischen Unterlagen sind bei den nachfolgend aufgeführten Personen erhältlich.

ITALIANO – DICHIARAZIONE DI CONFORMITÀ - Il fabbricante, Dutton-Lainson Company, Hastings, NE 68902-0729 USA, dichiara che il verricello di cui sopra è conforme alle disposizioni della direttiva 2006/42/CE. Il fascicolo tecnico può essere richiesto agli individui indicati qui di seguito.

PORTUGUÊS – DECLARAÇÃO DE CONFORMIDADE - A empresa Dutton-Lainson Company, Hastings, NE 68902-0729, nos E.U.A., fabrica o guincho acima identificado e declara que este cumpre todas as provisões relevantes da Directiva 2006/42/CE. Poderá obter o processo técnico junto das pessoas indicadas abaixo.

ESPAÑOL – DECLARACION DE HOMOLOGACION - Dutton-Lainson Company, de Hastings, NE 68902-0729 EE.UU., fabrica y declara que el cabrestante arriba identificado satisface todas las provisiones pertinentes de la directriz 2006/42/EC. El archivo técnico puede obtenerse de las personas mencionadas a continuación.

SVENSKA – FÖRSÄKRAN OM ÖVERENSSTÄMMELSE - Dutton-Lainson Company, Hastings, Nebraska 68902-0729 U.S.A, tillverkar och försäkrar att denna vinsch överensstämmer med alla tillämpliga bestämmelser i Direktiv 2006/42/EC. Den tekniska filen kan erhållas från de personer, som upptas nedan.

DANSK – ÖVERENSSTEMMELSESEKTLÆRING - Dutton-Lainson Company, Hastings, NE 68902-0729 USA fremstiller og erklærer, at skraldespillet identificeret ovenfor er i overensstemmelse med alle relevante krav i direktiv 2006/42/ER. Den tekniske fil kan rekvireres gennem de nedennævnte personer.

SUOMI – VAATIMUSTENMUKAISUUSVAKUUTUS - Dutton-Lainson Company, osoite Hastings, NE 68902-0729 U.S.A, vakuuttaa tämän vintturin valmistajana, että tämä vintturi noudattaa direktiivin 2006/42/EY olennaisia määräyksiä. Tekniset tiedot on saatavissa alla ilmoitetuilta henkilöiltä.

NORSK – SAMSVARSEKLÆRING - Dutton-Lainson Company, Hastings, NE 68902-0729 U.S.A. produserer og erklærer at vinsjen angitt ovenfor oppfyller alle relevante krav i direktivet 2006/42/EC. Den tekniske filen kan skaffes fra personene som er opplistet nedenfor.

NEDERLANDS – VERKLARING VAN OVERENSTEMMING - Dutton-Lainson Company, Hastings, NE 68902-0729 VS, fabrikant, verklaart dat de bovengenoemde lier voldoet aan alle betreffende bepalingen van richtlijn 2006/42/EC. Het technische bestand kan bij de hierna vermelde personen worden aangevraagd.

FRANÇAIS – DÉCLARATION DE CONFORMITÉ - Dutton-Lainson Company, Hastings, NE 68902-0729 U.S.A. construit le treuil mentionné ci-dessus et déclare qu'il répond à toutes les dispositions applicables de la Directive 2006/42/CE. Le dossier technique peut être obtenu auprès des personnes indiquées ci-dessous.

ΕΛΛΗΝΙΚΑ – ΔΗΛΩΣΗ ΣΥΜΜΟΡΦΩΣΗΣ - Η Dutton-Lainson Company, Hastings, NE 68902-0729 U.S.A. κατασκευάζει και δηλώνει ότι το βαρούλκο που καθορίζεται παραπάνω πληροί όλες τις σχετικές διατάξεις της Οδηγίας 2006/42/ΕΚ. Ο τεχνικός φάκελος είναι διαθέσιμος από τα άτομα τα οποία αναγράφονται παρακάτω.

Hastings, NE USA

January 4, 2010

Senior Vice President
Dutton-Lainson Company

Peter Munday

Bainbridge International Limited

Unit 8, Flanders Park, Flanders Road, Hedge End

Southampton, Hampshire, SO30 2FZ

ENGLISH-To obtain a copy of the warranty in English, send a self-addressed envelope to: Dutton-Lainson Company; P.O. Box 729; Hastings NE 68902-0729; U.S.A.

DEUTSCH-Wenn Sie eine deutsche Kopie der Garantbestimmungen erhalten möchten, senden Sie bitte einen adressierten Rückumschlag an: Dutton-Lainson Company; P.O.Box 729; Hastings NE 68902-0729; USA

ITALIANO-Per ricevere una copia della garanzia in italiano, inviare una busta riportante il proprio indirizzo a: Dutton-Lainson Company, P.O. Box 729, Hastings NE 68902-0729 USA.

PORTUGUÊS-Para obter uma cópia da garantia em português, envie um envelope com a sua morada para: Dutton-Lainson; P. O. Box 729; Hastings NE 68902-0729; E.U.A.

ESPAÑOL-Para obtener una copia de la garantía en español, envíe un sobre con su dirección impresa a: Dutton-Lainson Company, P.O. Box 729; Hastings NE 68902-0729 EE.UU.

SVENSKA-För att erhålla ett exemplar av garantin på svenska skicka ett adresserat kuvert till: Dutton-Lainson Company, P.O.Box 729, Hastings NE 68902-0729 U.S.A.

DANSK-Man kan få garantibeviset på dansk ved at sende en svarkuvert til: Dutton-Lainson Company, P.O. Box 729, Hastings NE 68902-0729, USA.

SUOMI-Takuuodistuksesta saa suomenkielisen kopion lähettämällä riittävällä postimaksulla ja vastaanottajan osoitteella varustetun kirjekuoren osoitteeseen Dutton-Lainson Company, P.O. Box 729, Hastings NE 68902-0729, USA.

NORSK-En kopi av denne garantien på norsk fås ved å sende en konvolutt med eget navn og adresse, til Dutton-Lainson Company, P.O. Box 729, Hastings NE 68902-0729, USA

NEDERLANDS-Voor een exemplaar van de garantie in het Nederlands dient u een aan u zelf geadresseerde enveloppe te zenden naar: Dutton-Lainson Company; P.O. Box 729; Hastings NE 68902-0729; U.S.A.

FRANÇAIS-Pour obtenir une copie de la garantie en français, envoyer une enveloppe à votre nom et adresse à : Dutton-Lainson Company; P.O. Box 729; Hastings NE 68902-0729; U.S.A.

ΕΛΛΗΝΙΚΑ-Για να λάβετε ένα αντίγραφο της εγγύησης στα Ελληνικά, στείλτε ένα φάκελο εσωκλείοντας τα ταχυδρομικά τέλη αποστολής στην εξής διεύθυνση: Dutton-Lainson Company, P.O.Box 729, Hastings NE 68902-0729 U.S.A.



DL3500

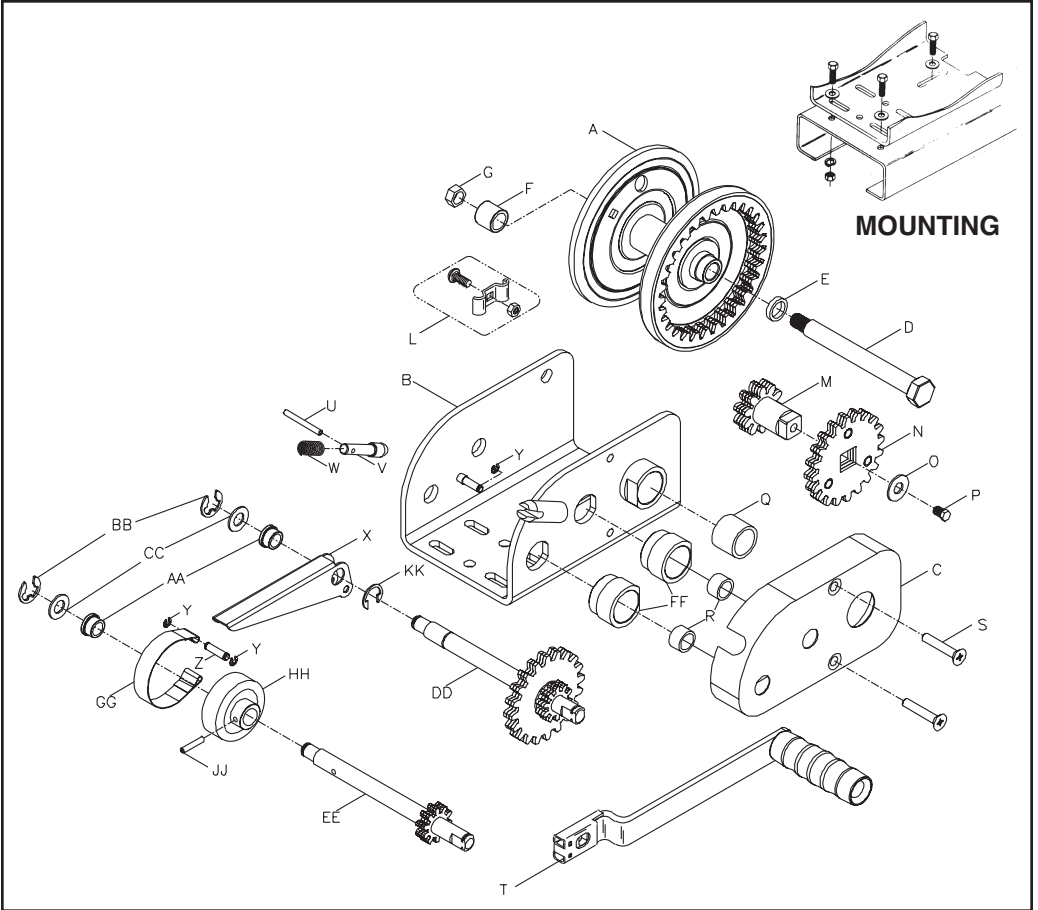

Ref	Description	Part No.
A	Reel	304156*
A	Reel-2½" Hub	304160*
A	Reel-3⅝" Hub	304161*
B	Base	304480*
C	Gear Cover	404365*
D	Shoulder Bolt	204145
E	Gear Side Spacer	404372
F	Rope Side Spacer	404373
G	Locknut	205015
L	Rope Clamp Kit	304321
M	Short Drive Shaft	304194
N	20 Tooth Gear	304174
O	Washer	205044
P	Screw	205121
Q	Needle Bearing	205133
R	Needle Bearing (2)	205183
S	Cover Screws (2)	205125

Ref	Description	Part No.
T	Handle	5703301
U	Roll Pin	206549
V	Ratchet Plunger	404374
W	Ratchet Spring	204143
X	Brake Handle	404387
Y	Retaining Ring (3)	205020
Z	Clevis Pin	404045
AA	Bearing (2)	204148
BB	Retaining Ring (2)	205012
CC	Washer (2)	205120
DD	Inter. Drive Shaft	304532
EE	Primary Drive Shaft	304531
FF	Drive Shft. Bear. Hous. (2)	404476
GG	Brake Band	404389
HH	Brake Drum	304179
JJ	Roll Pin	205117
KK	Retaining Ring	205116

*Specify Color When Ordering

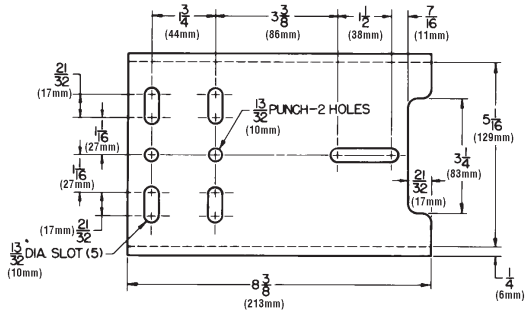
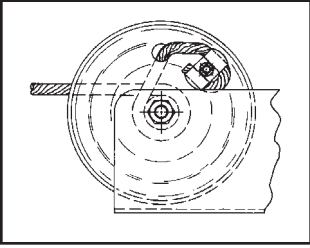

To order replacement parts contact:

Dutton-Lainson Company

www.dlco.com

Tel: 800-569-6577

Fax: 402-460-4612

e-mail: DLsales@dutton-lainson.com

In Europe Contact:

Aqua-Marine International Ltd.

8 Flanders Park

Hedge End, Southampton

Hants, England SO30 2FZ

Tel: +44 (0) 1489-776050

Fax: +44 (0) 1489-776055

e-mail: sales@aqua-marineint.co.uk